



► **BMM SWING BLOCK**

Galvanized.

► **BMM KASTBLÖKK**

Galvaniseruð.

► **BMM-SVING BLOK**

Galvaniseret.

► **BMM PASTECA  
ABRIDORA**

Galvanizadas.

► **БЛОКИ  
ЖЕСТКОЙ  
ФИКСАЦИИ  
BMM**

Оцинкованные.

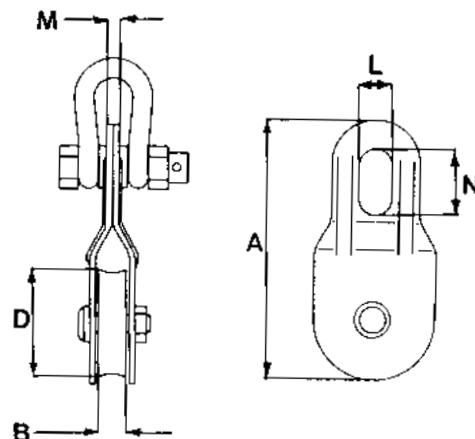

Part no. Vörunr. Vare nr. Parte no. № изд.	SWL 5:1	A	B	D	M	L	N	Max wire	Weight Þyngd Vægt Peso Вес
	ton	mm	mm	mm	mm	mm	mm	mm	kg
KSW1G	1	190	22	80	13	23	48	16	1,0
KSW1NG*	1	190	30	80	13	23	48	24	1,2
KSW21G	2	255	24	110	15	28	56	18	2,9